

BOBCAT

INTELLIGENT CAMERA SERIES

ICX-B1410



The ICX-B1410 is an advanced progressive scan, fully programmable CCD camera designed for imaging applications that require high quality images, powerful features and flexibility. The camera has a small size, is light weight, and built around Sony's ICX-285 6.45 micron Interline Transfer CCD image sensor with a 2/3" optical format.

The ICX-B1410 provides an image resolution of 1392 x 1040 and delivers up to 30 frames per second at full resolution. The camera's 14 bit internal data image processing engine is based on an industrial grade high-speed, high-density FPGA, enabling a broad standard feature set and easy implementation of demanding custom imaging solutions. The thermally optimized, mechanical and electrical design plus the extended operating temperature range (-40°C to +85°C), and high MTBF of 660,000 hrs @ 40C, make this camera a perfect fit for the most demanding industrial, medical, scientific and military applications.

Features

1392/1360 x 1040/1024

Mono and color - 8/10/12/14-bit data

Normal and over-clock operation (23/30 fps)

CoaXPress with PoCXP support

Analog and digital gain and offset control

1x, 2x, 3x, 4x, 8x horizontal and vertical binning

Eight (8) independent horizontal and vertical AOIs

Programmable horizontal and vertical resolution

Programmable line time, frame time and speed

Programmable external trigger

Internal/External exposure control

Standard, fast, frame accumulation, double and asynchronous triggering modes

Automatic gain, exposure and iris control

Automatic white balance

Internal/External H and V sync input/output

Left/right digital bit shift

Test image with image superimposition

Built in pulse generator

Programmable I/O mapping

Dynamic transfer function correction

Dynamic black level correction

Defective and hot pixel correction (static/dynamic)

Temperature monitor

Field upgradeable firmware

Customer defined Look Up Table (LUT)

Two dimensional Flat Field Correction (optional)

Reverse image (H mirror) (optional)

MTBF of 660,000 hrs. @ 40°C.

Applications

Aerial Mapping

Aerospace

Automation

Biometrics

Broadcasting

Electronics

Flat Panel Inspection

Food Safety

Homeland Security

Industrial Applications

ITS

Military

Medical/Scientific Imaging

Semiconductors

Solar

Space Exploration

Robotics

Surveillance

...and more



BOBCAT ICX-B1410 Specifications

Maximum Resolution	1392 x 1040
Sensor Type	2/3" CCD ICX 285
Pixel Size	6.45 μm
Frame Rate	23/30 fps (normal/overclock)
Max Frame Rate	190 FPS
Minimum S/N ratio	60 db
Video Output	CoaXPress with PoCXP
Output Format	8, 10, 12, 14 bit single, 3x8 RGB
Binning H & V	x1, x2, x3, x4, x8
Area of Interest	8 independent AOIs, 2 x 2 to 1392 x 1040
Shutter Speed	1/500,000 to 1/23 sec (nom)
Long Integration	Up to 16 sec
Gamma Correction	G=1.0, G= 0.45, user upgradable LUT
Video Gain	36 dB range, 1024 steps, 0.0351 dB per step
Exposure and AGC	Manual, Auto, Programmable
Iris Control	Auto, Programmable
Strobe Output	Programmable position and duration
Image Overlay	Yes, Programmable
Cam Configuration	Gen<i>Cam

Data Corrections	DPC, HPC, LUT, FFC
Hardware Trigger	LVTTTL or TTL via IN1/IN2, level, edge, pulse-width, programmable
Software Trigger	Software internal, level, edge, pulse-width, programmable
Trigger Modes	Programmable, standard, double exposure, fast, frame accumulation, asynchronous
Min. Illumination	0.2 Lux, F/1.4
Power Consumption	3.6 W, 150 mA @ 24V steady, 1.5 A inrush
Size (W x H x L)	46 x 46 x 54mm
Weight	190g
Lens Mount	C mount
Vibration, Shock	10G (20 - 200) Hz XYZ, 70G
Environmental	Operation (-40° to +85°)C Storage (-40° to +90°)C
Humidity	10% to 90% non-condensing
MTBF	660,000 hrs. @ 40°C
Regulatory	FCC 15 part A, CE, RoHS

I/O Interface:



1 N/C	7 OUT1 Signal
2 N/C	8 IN1 Signal
3 IRIS VCC	9 IN2 Signal
4 IRIS Video	10 IN1/2 Return
5 IRIS Return	11 Reserved
6 OUT1/2 Return	12 OUT2 Signal

Connector: Hirose HR 10A-10R-12PB(71)

Lens Control:

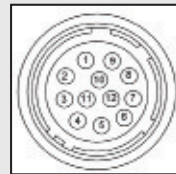

1 IRIS Return	7 Lens CTRL4
2 IRIS VCC	8 Lens CTRL5
3 IRIS Video	9 Lens CTRL6
4 Lens CTRL1	10 AUX UART COM
5 Lens CTRL2	11 AUX UART RX
6 Lens CTRL3	12 AUX UART TX

Connector: Hirose HR 10A-10R-12SB(71)

Order Options: ICX- B1410M-SCO Monochrome CoaXPress Output
ICX- B1410C-SCO Color CoaXPress Output

For specific details and ordering information, consult the camera user's manual or contact IMPERX at sales@imperx.com.

Spectral Response

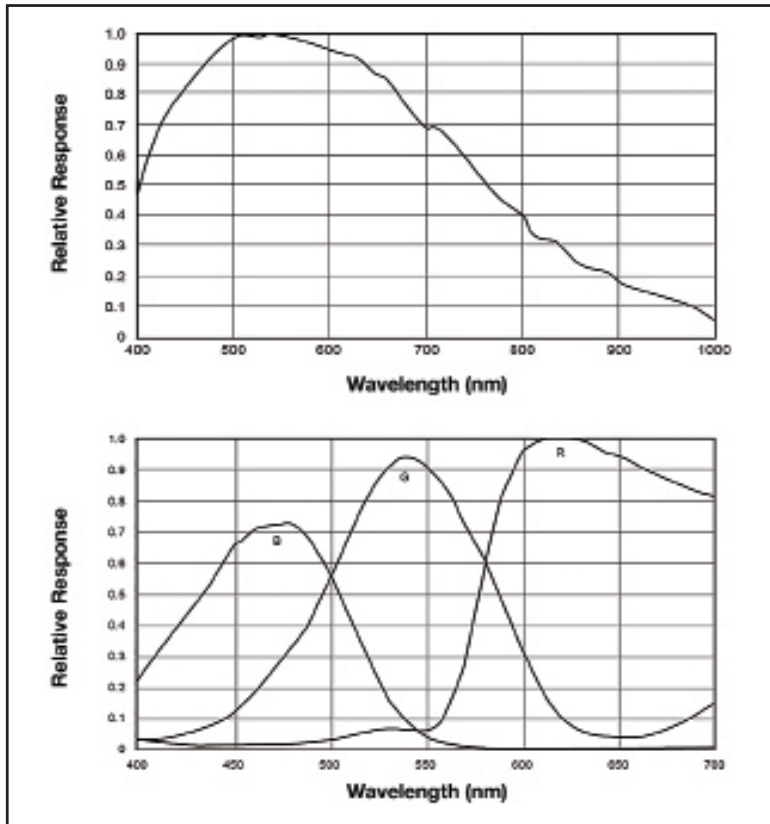

Mechanical Dimensions

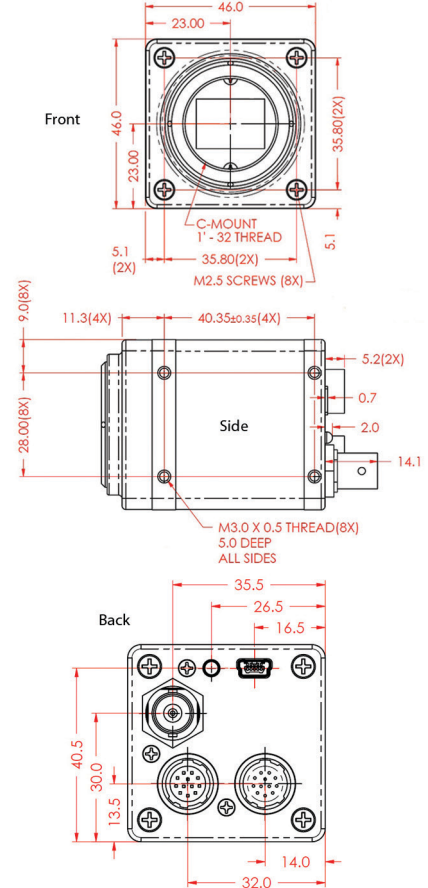

IMPERX | 6421 Congress Avenue | Boca Raton | FL 33487 | USA
Phone: +1-561-989-0006 | 1-866-849-1662 | Fax: +1-561-989-0045
www.imperx.com | sales@imperx.com

Copyright © 2011, Imperx, Inc. Product information subject to change without notice. Rev. 1 10/2011

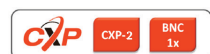

Made in USA