



**STC-UE54**

**(1/4" Low-Resolution Monochrome)**

**STC-HUE64**

**(1/4" High-Resolution High-Sensitivity Monochrome)**

# **Product Specification**

**Item Number Designation**

**COM-ICX226AL: CCD ICX226AL**

**COM-ICX278AL: CCD ICX278AL**

**COM-UN64RBN: Flex board assembly without CCD**

**COM-UE54CCU: CCU board with wire harnesses for COM-ICX226AL**

**COM-HUE64CCU: CCU board with wire harnesses for COM-ICX278AL**

**Complete cameras are composed with the following combinations:**

**STC-UE54: COM-ICX226AL + COM-UN64RBN + COM-UE54CCU**

**STC-HUE64: COM-ICX278AL + COM-UN64RBN + COM-HUE64CCU**

## Safety Precautions

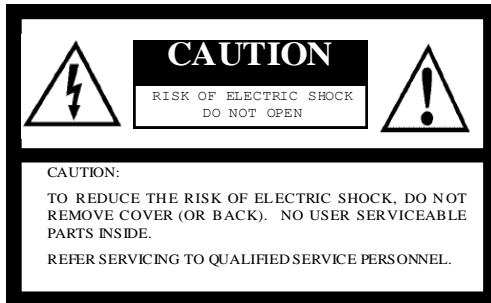

The lightning flash with arrowhead symbol, within an equilateral triangle, is intended to alert the user to the presence of uninsulated “dangerous voltage” within the product’s enclosure that may be of sufficient magnitude to constitute a risk of electric shock to persons.



The exclamation point within an equilateral triangle is intended to alert the user to the presence of important operating and maintenance (servicing) instructions in the literature accompanying the appliance.

For U.S.A.

### Warning:

This equipment generates and uses radio frequency energy and if not installed and used properly, I.e., in strict accordance with the instruction manual, may cause harmful interference to radio communications. It has been tested and found to comply with the limits for a Class A computing device pursuant to Subpart J of Part 15 of FCC Rules, which are designed to provide reasonable protection against such interference when operated in a commercial environment.

For Canada

### Warning:

This digital apparatus does not exceed the Class A limits for radio noise emissions from digital apparatus set out in the Radio Interference Regulations of the Canadian Department of Communications.

### WARNING:

TO PREVENT FIRE OR SHOCK HAZARD, DO NOT EXPOSE THIS APPLIANCE TO RAIN OR MOISTURE.

## Product Precautions

- Handle the camera with care. Do not abuse the camera. Avoid striking or shaking it. Improper handling or storage could damage the camera.
- Do not pull or damage the camera cable.
- During camera use, do not wrap the unit in any material. This will cause the internal temperature of the unit to increase.
- Do not expose the camera to moisture, or do not try to operate it in wet areas.
- Do not operate the camera beyond its temperature, humidity and power source ratings.
- While the camera is not being used, keep the lens or lens cap on the camera to prevent dust or contamination from getting in the CCD or filter area and scratching or damaging this area.
- Do not keep the camera under the following conditions:
  - In wet, moist, and high humidity areas
  - Under hot direct sunlight
  - In high temperature areas
  - Near an object that releases a strong magnetic or electric field
  - Areas with strong vibrations
- Use a soft cloth to clean the camera. Use pressured air spray to clean the surface of the glass. DO not scratch the surface of the glass.

## Copyright & Disclaimer

Sensor Technologies America, Inc. (DBA Sentech America) believes the contents and specifications of its website, catalog, documentation and ads are correct; however, Sentech America provides no representation or warranty regarding such information or products(s) contained therein. It is requested that Sentech America be given appropriate acknowledgement in any subsequent use of such work by a third party.

While every effort has been made to ensure that the details contained in Sentech America's website and all documentation are correct and up-to-date, Sentech America assumes no liability, legal or otherwise for any errors in listings, specifications, part numbers, process, software or model applications. Sentech America reserves the right to change specifications, product descriptions, product quality, pricing and application at any time without prior written or oral notice. Any party using such information assumes all risk for any and all damaged caused to themselves, a third party and/or property by virtue of incorrect information and/or failure of these products. By installing and/or using a Sentech America software development kit or other similar product and/or information obtained from Sentech America's website, catalog, documentation or ads, you hereby accept and understand these stated terms and conditions.

## Content

<b>I. Specifications</b> .....	<b>5-7</b>
A. Electronic Specifications / Mechanical Specifications / Environmental Conditions.....	5
B. Connector Specifications .....	6
1. The connector for the power and the video (CN1).....	6
2. The connector for the RS232C communication (CN2).....	6
3. The connector for the FPC cable of the CCD unit (CN3) .....	6
C. Cable Specifications .....	7
<b>II. Dimensions</b> .....	<b>8</b>

## I. Specifications

### A. Electronic Specifications / Mechanical Specifications / Environmental Conditions

Product		STC-UE54	STC-HUE64	
Electronic Specifications	Imager	1/4" low-resolution interline EIA CCD: ICX226AL (Sony)	1/4" high-resolution high-sensitivity interline EIA CCD: ICX278AL (Sony)	
	DSP	R2A45201BG (Renesas)		
	Effective Picture Elements	512 (H) x 492 (V)	768 (H) x 494 (V)	
	Chip Size	4.34 (H) x 3.69 (V) mm	4.43 (H) x 3.69 (V) mm	
	Cell Size	7.15 (H) x 5.55 (V) μm	4.75 (H) x 5.55 (V) μm	
	Scanning System	2:1 Interlace		
	Vertical Frequency	59.94 Hz		
	Horizontal Frequency	15.734 kHz		
	Horizontal Resolution	380 TV Lines	570 TV Lines	
	S/N Ratio (Standard Deviation)	More than <b>TBD</b> dB		
	Minimum Scene Illumination	<b>TBD</b> Lux at F1.4	<b>TBD</b> Lux at F1.4	
	Sync. System	Internal / External (Automatically switch)		
	Video Output	1.0 Vp-p 75 Ohm, Y/C RS-170 and NTSC standards compatible. Both composite and Y/C.		
	Electronic Iris	1/1 to 1/10,000 seconds		
	Gain	AGC ON		
	Gamma	0.45		
	Mirror Image	Normal / Horizontal / Vertical / Horizontal and Vertical (180 deg. retated image) mirror image		
	Power Supply	Input Voltage	DC 4.5 to 5.5 V	
		Consumption	Less than 1.0 W	
	Communication	RS232C via CN2 (SM04B-SRSS-TB) connector		
Character Generator	Control via RS232C communication			
Mechanical Specifications	Dimensions	Head module	10 (H) x 44 (W) x 3.65 (D) mm	
		CCU	38 (H) x 75 (W) x 5 (D) mm	
	Optical Filter	None		
	Lens Mount	None		
	Interface Connector	SM10B-SRSS-TB for Video and power, SM04B-SRSS-TB for communication		
	Weight	<b>TBD</b> g		
Environmental Conditions	Temperature & Humidity	Operational	Temperature: -5 to 45°C; Relative Humidity: 0 to 85% (No Condensation)	
		Storage	Temperature: -30 to 65°C; Relative Humidity: 0 to 90% (No Condensation)	
	RoHS	RoHS Compliant		

## B. Connector Specifications



### 1. CN1: The connector for the power and the video

Connector Type: SM10B-SRSS-TB (Right angle connector, JST)  
Pin Assignment:

No.	Signal Types
1	DC +5V IN
2	GND
3	VIDEO OUT
4	GND
5	HD IN
6	VD IN
7	Y OUT
8	C OUT
9	NC
10	GND

### 2. CN2: The connector for the RS232C communication

Connector Type: SM04B-SRSS-TB (Right angle connector, JST)  
Pin Assignment:

No.	Signal Types	Voltage
1	DC +3.3V	3.3V
2	TxD	High: 2.5 to 3.3V Low: 0.0 to 0.8V
3	RxD	High: 2.8 to 3.3V Low: 0.0 to 0.8V
4	GND	

### 3. CN3: The connector for FPC cable of the CCD unit

Connector Type: 14FHJ-SM1-TB (JST)

### III. Cable Specifications

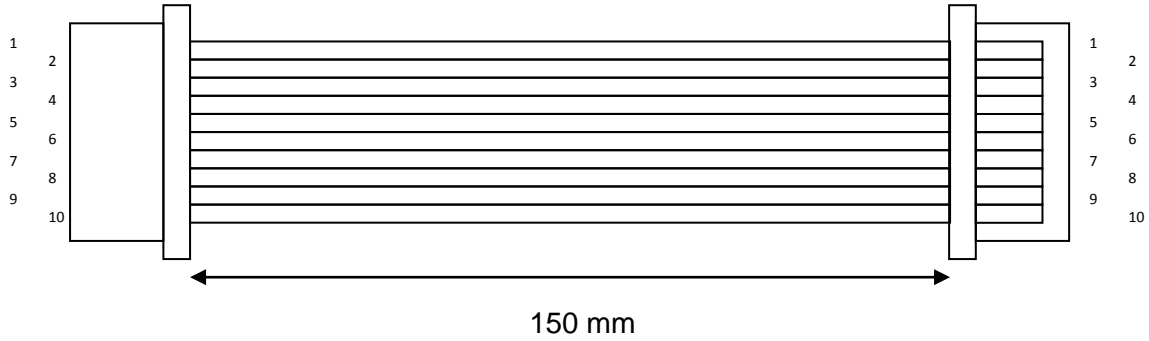

Connector 1 SHR-10V-S-B (JST)		
No.	Signal Types	Wire Color
1	DC +5V IN	Brown
2	GND	Red
3	VIDEO OUT	Orange
4	GND	Yellow
5	HD IN	Green
6	VD IN	Blue
7	Y OUT	Purple
8	C OUT	Gray
9	NC	White
10	GND	Black

Connector 2 SHR-10V-S-B (JST)		
No.	Signal Types	Wire Color
1	DC +5V IN	Brown
2	GND	Red
3	VIDEO OUT	Orange
4	GND	Yellow
5	HD IN	Green
6	VD IN	Blue
7	Y OUT	Purple
8	C OUT	Gray
9	NC	White
10	GND	Black

## IV. Dimensions

CCU absolute maximum thickness including all components and connectors: **Less than 5.3mm**

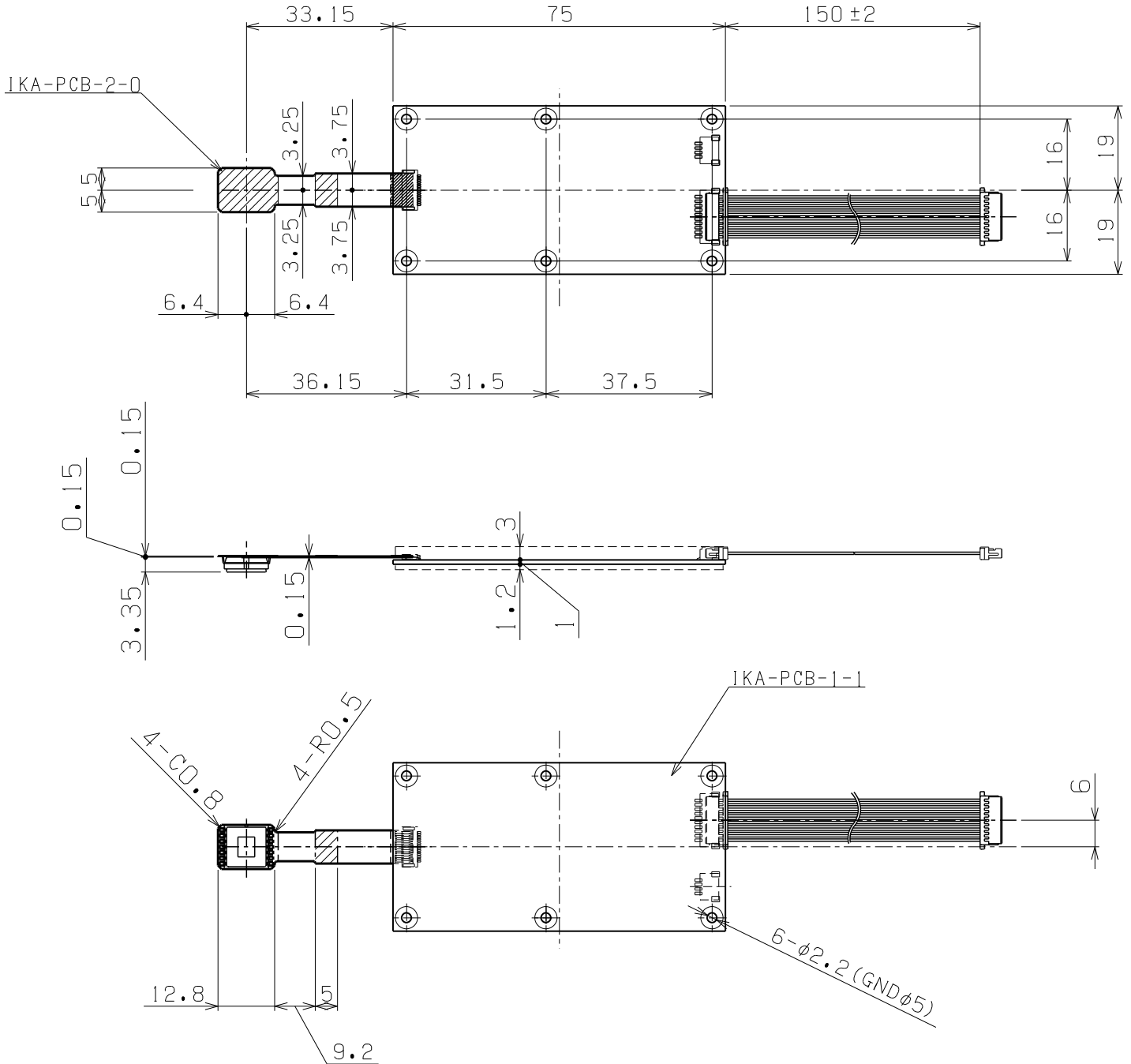

Unit: mm

## Revisions

Rev	Date	Changes	Note
0.0	2008/11/18	Create document	
0.1	2008/11/18	Addition (green) was made by Mizuno	
0.2	2008/11/19	Addition (blue) was made by Aimono	
0.3	2008/11/20	Clean up the document was made by Aimono	
0.4	2008/12/05	Addition was made by Aimono 1) Add "Character generation" function to the specifications 2) Add the thickness of the CCU board to the dimensions 3) Add the additional mount hole on the PCB board	
0.5	2009/01/21	Update 1) Change the camera input voltage from "12V" to "5V"	
0.6	2009/02/04	Update 1) Add the voltage range of the Txd and the Rxd signals	
1.0	2009/02/20	Update for ES2 1) Change the camera input voltage from "DC 5V" to "DC 4.5 to 5.5V" 2) Change the pin assignment of CN2 for the communication 3) Change the dimensions of the camera	
1.1	2009/02/24	Update 1) Change the dimensions of the camera	

**Sensor Technologies America, Inc.**

1345 Valwood Pkwy, Suite 320  
Carrollton, Texas 75006-6891  
TEL (972) 481-9223 FAX (972) 481-9209  
URL <http://www.sentechamerica.com/>

**Sensor Technology Co., Ltd.**

7F, Harada Center Building  
9-17, Naka cho 4chrome  
Atsugi-city, Kanagawa  
243-0018 Japan  
TEL +81-46-295-7061 FAX +81-46-295-7066  
URL <http://www.sentech.co.jp/>

**Taiwan Sensor Technology, Inc.**

3F-6, No. 9, Aiguo W, Rd., Jhong Jheng District  
Taipei City 100, Taiwan, R.O.C.  
TEL 886-2-2383-2331 FAX 886-2-2370-8775  
EMAIL: sentech0501@yahoo.com.tw